

High Speed

Extruded Aluminum Cross Tubes
Molded Pushers
Sound Insulation For Noise Reduction

Nominal System Widths:
24", 30" & 36"

Sort Rate Capacity:
Up to 150 Cartons Per Minute at speeds up to 500 Feet Per Minute. Sort rate is dependant upon carton size & weight, required gap between products, and system design.

Carton Weight Capacity:
Up to 200 pounds, depending on sort rate and system design.

Air Requirements:
Nominal operating pressure is 65 psi.



Ideally suited for heavy duty applications, Automotion's AutoSort 13 Sliding Shoe Sortation Conveyor is a high speed, positive divert sorter that is designed to accurately track and gently sort all types of carton sizes and configurations at designated points along the transportation line with a totally reliable sort rate. A wide range of packaged goods and materials, in virtually any mix are easily and conveniently transported to their assigned zones at high sortation speeds. Automotion's modularly designed Sliding Shoe Sorter Conveyors represent the ultimate in sortation systems that depend on both tracking and sorting within the system.

Product to be sorted is tracked and diverted by pushers (sliding shoes) which are designed to operate from the inside of the extruded carrying tubes through a slot running the length of the extrusion. This allows for free, unobstructed operation even when the carrying surface of the slat becomes contaminated with debris. The load carrying cross tube assemblies are bolted to one pair of attaching links on the heavy duty #120 double pitch roller chain. Internal, pneumatically operated switch stations located beneath the carrying tubes guide the sliding shoe pushers. Ball bearing wheels on all working load components have been applied in lieu of wear strips, greatly reducing drive train load pull requirements and chain stretch.

The air operated switch stations are modular units designed to be serviced through the top of the conveyor for easy, unobstructed access. Automotion's high speed sliding shoe sortation units allow for unparalleled flexibility in designing a dependable sortation system limited only to the size and scope of the transportation system itself.



Typical Applications:
Shipping Sortation
Receiving Sortation

Sortation Conveyor Live Load Capacity:
Up to 100 lbs/ft. depending on width, roller centers, supports, etc.

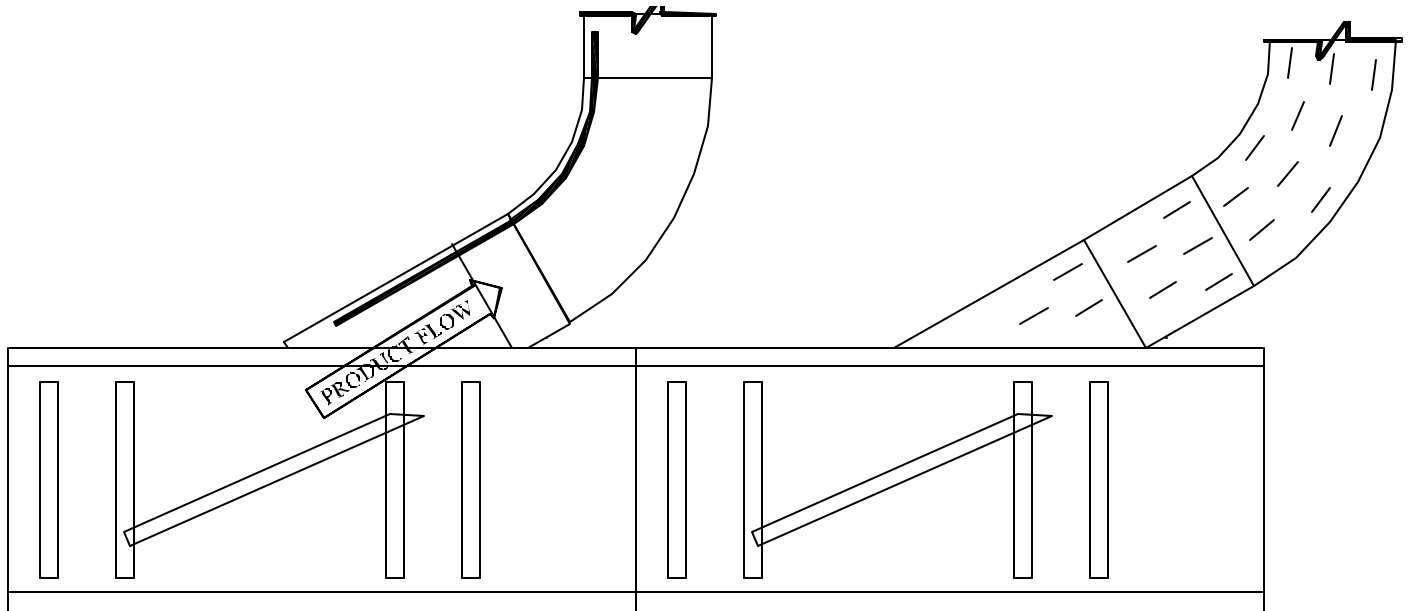

Nominal System Widths:
24", 30" & 36"

Nominal Divert Switch Angles:
20° and 28° dependent upon sort conveyor speed and system design.

Divert Configurations:
Single side divert, right or left side. Dual side divert station having directly opposing divert lanes. Number of divert stations and minimum station centers limited by carton size, distance between diverts, angle of divert switch track, and conveyor pull requirements.

Safety Jam Switch Detectors:
Each switch station has an internal override jam switch detector to shut down the conveyor in the remote chance a pusher escapes the track.

Options:
Various Floor & Ceiling Supports
Full Length Bottom Covers (20' bottom covers included at each end standard).

Integral Belt Conveyor Infeed Unit:

The AutoSort also includes an integral belt conveyor infeed unit that works in conjunction with the terminal end/chain take-up arrangement to provide a consistent transition of product at all times onto the sorter carrying tubes without moving the entry location of the sorter.

Easy Maintenance & Reliability:

Entire tube and pusher assembly can be removed from the top of the conveyor by removing only four (4) bolts. This will expose the divert switch assembly which can also be taken out from the top by removing only four (4) bolts. This modular construction of components, extruded aluminum carrying tube assemblies, high strength, low friction plastic materials for pusher slides and divert switch blocks, greatly reduces maintenance and adds to machine longevity.

