

Medium Speed

Nominal Conveyor Widths:

24", 30" & 36"

Sort Rate Capacity:

Up to 20 Cartons Per Minute on Sortation Belt Conveyor running 100 to 250 Feet Per Minute. Sort rate is dependant upon carton size & weight and system design.

Carton Weight Capacity:

Up to 75 pounds, depending on sort rate and system design.

Compatible Conveyor:

Automotion high speed slick top belt sortation conveyor.

Air Requirements:

Nominal operating pressure is 80 psi.

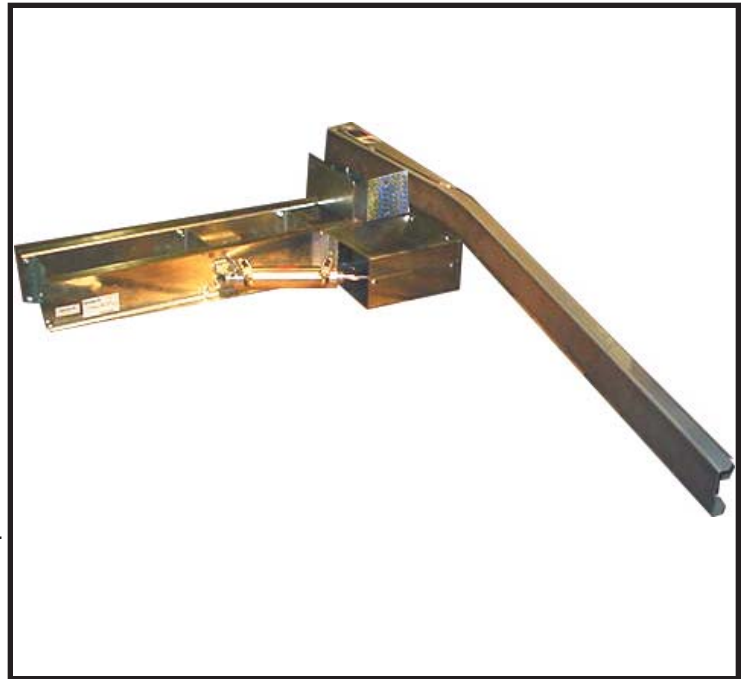

Automotion's Trap Arm Sorter can be used as an integral sortation component in almost any conveyor system. Automotion's High Speed Induction Conveyor strategically gaps and places the product onto the Automotion Sortation Belt Conveyor. The Trap Arm Diverter gets fired to the fully divert position prior to the carton reaching the arm. The trap arm diverts the product from the sort conveyor onto a powered or non-powered take-away conveyor for further disposition. This diverter will change the orientation of the product by 90 degrees from the sortation conveyor through the take-away.

The Trap Arm Sorter provides flexibility and effectiveness in handling and separating a wide range of packaged goods and materials. The arm is air operated and can be controlled manually or remotely to meet your specific sortation requirements.

For added flexibility, the medium speed trap arm sort stations are designed to be used with Automotion's standard belt conveyor fitted with slip top belting.

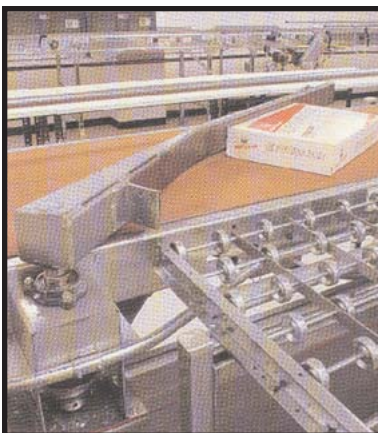
**Typical Applications:**

Shipping Sortation
Receiving Sortation

Sortation Belt Conveyor Live Load Capacity:

Up to 100 lbs/ft. depending on width, roller centers, supports, etc.

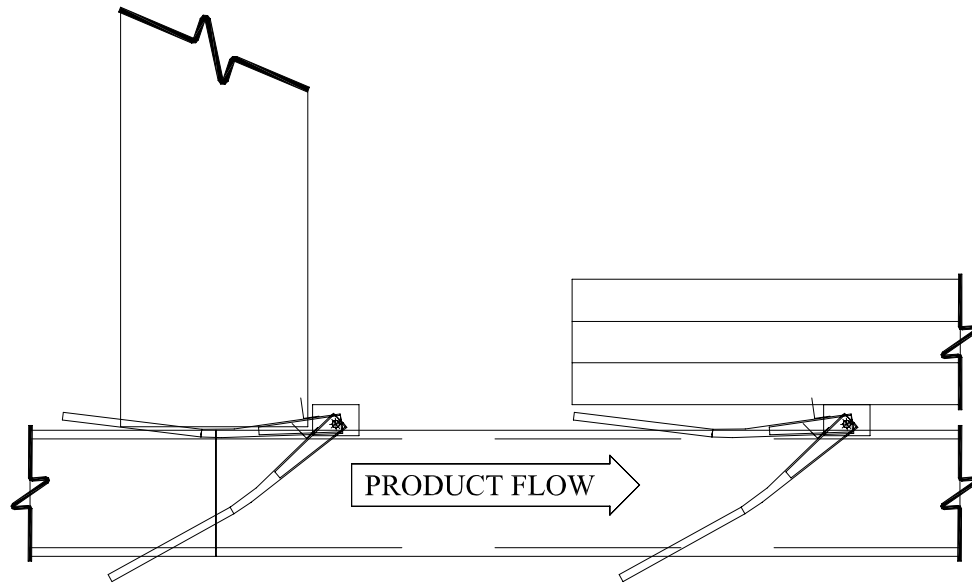

11000 South Laverne Avenue Oak Lawn, Illinois 60453-5500
Phone: 708-229-3700 Fax: 708-229-3799
www.automotionconveyors.com
info@automotionconveyors.com