

Bed Section:

5 1/4" Deep x 12 Gauge galvanizid frame in 6" increments between 12" and 144".

Galvanized Carrying & Belt Return Rollers:

1 7/8" Diameter, 16 Gauge, carrying rollers with 7/16" hex axle. Return rollers on nominal 6' centers, carrying rollers on nominal 6" centers.

Drives:

6", 8", or 10" Center Drives and 6" or 8" End Drives. Lagged pulley with automatic spring take-up on center drive. Fully enclosed chain and sprockets.

3/4 HP to 5 HP 230V-460V/3-Phase/60Hz. "C" face TEFC motor with reducer. Speed range is 60-320 FPM.

Termnal End:

4", 5" or 6" Diameter plain pulley with pop-out roller.

Belting:

Type 1 Friction Surface X Bare Surface.

Axle Isolators:

A specially designed conductive plastic insert isolates all return roller axles from the conveyor frame to reduce noise and prevent wear caused by axle movement and vibration.



All of the advantages and benefits that make a big difference in durability and performance are built into each facet of Automotion's pre-engineered conveyor components.

Automotion's Roller Bed Belt Conveyor make it easy to transport a wide variety in shapes and sizes, up to 100 pounds per foot, to specified destination points in level surface applications as well as in incline and decline applications. Automotion's Roller Bed Belt Conveyors are well supported units that are stable, quiet running , versatile and economical. These units feature extra-strength, non-exposed axle design, a variety of drives and take-up options, built-in box channel design for safety and appearance, are available in multiple widths to meet your requirements. Automotion's Roller Bed Belt conveyors use C-Faced motors which provide adjustability and variability via reducers to meet speed requirements. All mechanical operations run smoothly and quietly.

Typical Applications:

Transportation
Elevation Changes
Sortation
Trash Conveyor
Pick Belts

Live Load Capacity:

Up to 130 lbs/ft. depending on width, roller centers, supports, etc.

Nominal Widths:

18", 24", 30", 36", 42" & 48"

Standard Belt Widths:

14", 20", 24", 30", 36" & 42"

Carrying Roller Centers:

6" & 9"

Options:

Various Take-Up Options
Various Guard Rail Options
Various Floor & Ceiling Supports
High Speed Rollers (standard for speeds greater than 180 FPM).
Power Take-Off Units
Drop Kit
Bottom Covers
Terminal End Covers
Pop-Out Roller at Terminal End
Punch for Top Mount Guard Rail
Synchronous Belt Drive
Cog Belt Drive

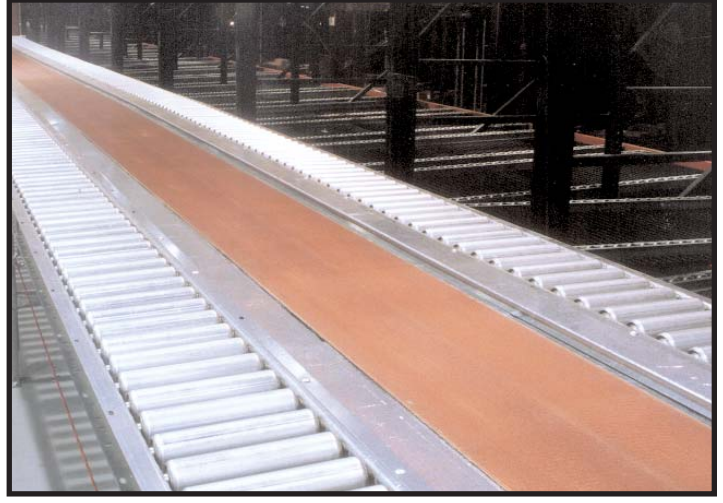
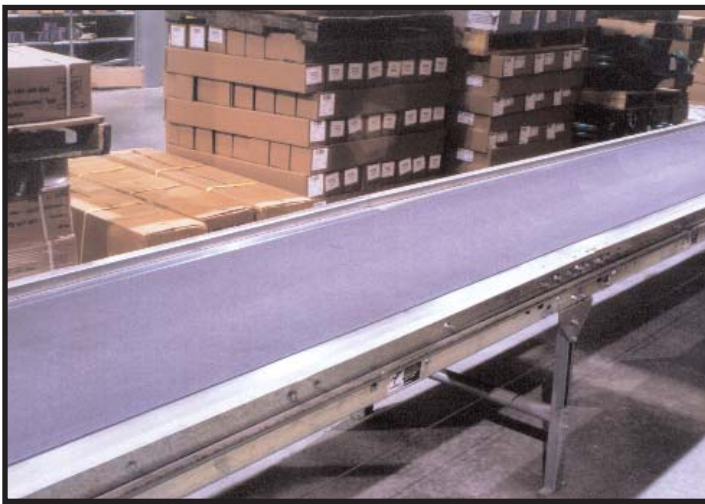
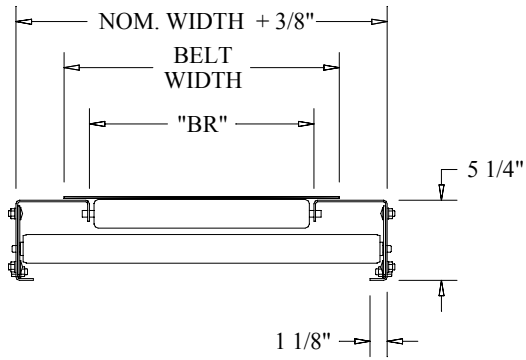
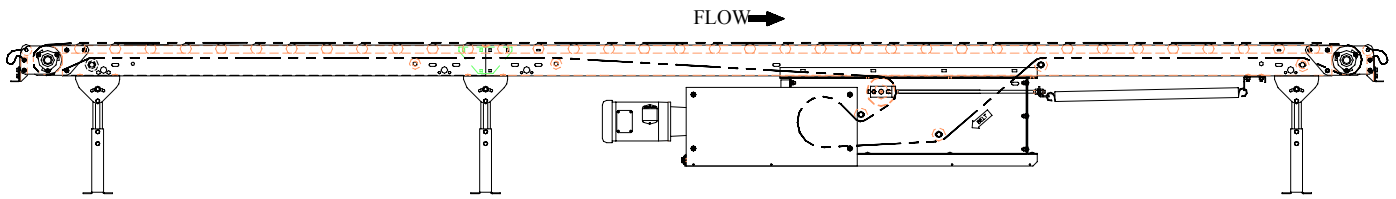

11000 South Lavergne Avenue Oak Lawn, Illinois 60453-5500
 Phone: 708-229-3700 Fax: 708-229-3799
www.automotionconveyors.com
info@automotionconveyors.com