

High Speed

Divert Assembly:

Three rows of slave driven, skewed divert wheels are mounted in a carriage get raised above the sorter plane, changing the case direction in a positive manner.

Nominal System Widths:

24", 30" & 36"

Sort Rate Capacity:

Up to 90 Cartons Per Minute on Sortation Belt Conveyor with speeds ranging from 180 - 300 Feet Per Minute. Sort rate is dependant upon carton size & weight and system design.

Carton Weight Capacity:

Up to 75 lbs, depending on sort rate and system design.

Compatible Conveyor:

Automotion high speed slick top belt sortation conveyor.

Air Requirements:

Nominal operating pressure is 80 psi.



Automotion's three row Pop-Up Wheel Sorter Conveyor system handles a wider range of carton sizes, operates with a more positive sort rate and performs with outstanding accuracy. Modular in design, Automotion's Pop-Up Wheel Sorter Conveyors have beneficial and advantageous quality features built into every facet of each component of this sortation system.

Automotion's units allow for unparallelled flexibility in designing a sortation system. The restrictions for numbers of diversion points are imited only to the size and scope of the transportation systemm itself. And, there is unlimited overall sorter lengths available, providing countless diversion configurations that surpass the flexibility of almost any other sorter. For added flexibility, the Pop-Up Wheel Sort Stations are designed to be compatible with Automotion's standard belt conveyor fitted with slip top belting.

Three rows of wheels are used to insure a more positive sort rate. Product is diverted at 45° onto a take-away conveyor for further disposition.

These units are designed for fast service and easy maintenance. The pivoting pop-up wheel carriage assembly can be removed from the top of the divert station. Divert wheels are driven by 1/4" diameter urethane belts which are easily changed by unbolting one end of the drive spindle shaft. The main urethane drive belts are externally mounted for easy access. These features greatly reduce maintenance downtime and adds to machine reliability.

Typical Applications:

Shipping Sortation
Receiving Sortation

Sortation Belt Conveyor Live Load Capacity:

Up to 100 lbs/ft. depending on width, roller centers, supports, etc.

Nominal System Widths:

24", 30" & 36"

Standard Belt Widths:

20", 24" & 30"

Divert Configurations:

Single side divert, right or left side. Main line sort belt with individual drives can be linked together in a series to provide any number of diverts. Minimum 69" divert station centers.

Options:

Various Take-Up Options
Various Guard Rail Options
Various Floor & Ceiling Supports
High Speed Bearings (standard for speeds greater than 180 FPM).
Power Take-Off Units
Drop Kit
Bottom Covers
Terminal End Covers
Pop-Out Roller at Terminal End

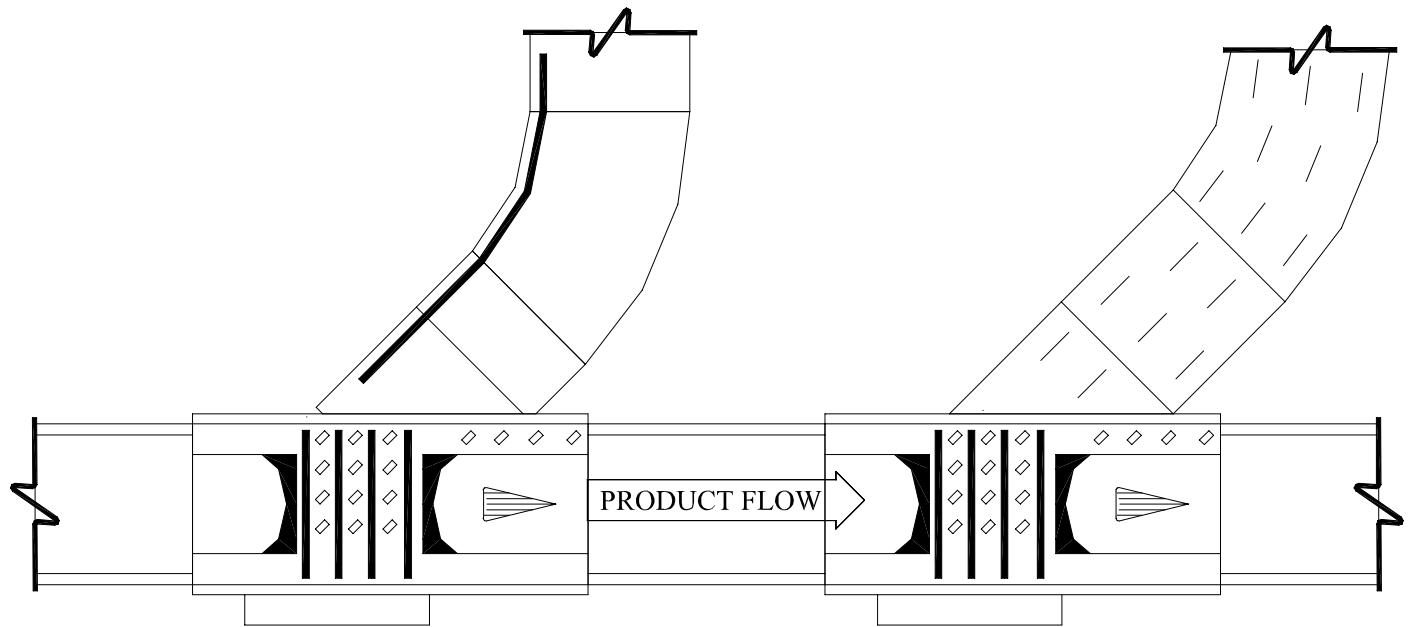

11000 South Laverne Avenue Oak Lawn, Illinois 60453-5500
 Phone: 708-229-3700 Fax: 708-229-3799
www.automotionconveyors.com
info@automotionconveyors.com