

**Materials Handling Products**

- Heavy Duty Drive
- High Speed
- Long Units
- E-Z Trac<sup>®</sup> Pulleys

Model 406 Walk Pick conveyor features heavy duty components for long lengths with a single drive. It offers savings over multiple units of regular duty equipment for long pick modules.

**Operation:** One-way, horizontal.

**Capacity:** 150 lb/ft.

**Speeds:** 90, 110, 150, 200 and 250 fpm.

**Conveying Surface Height:** 24" 27", or 30".

**Drives:** 2000 lb pull end or center drive, 16" diameter pulley with molded-on lagging, 2-15/16" diameter shaft with 2-7/16" diameter ends, mounted in self-aligning bearings.

**Motor and Reducer:** 7-1/2 or 10 hp, C-face.

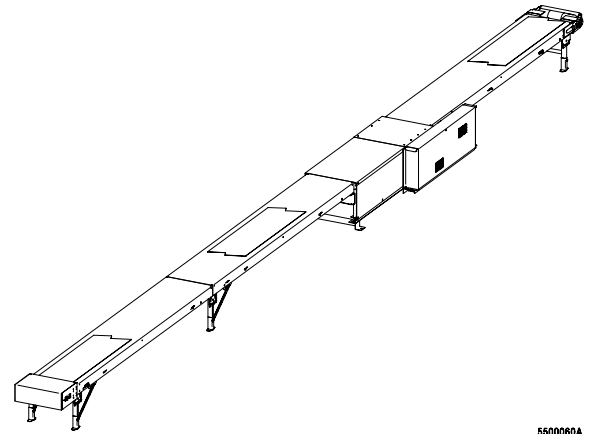

5500060A

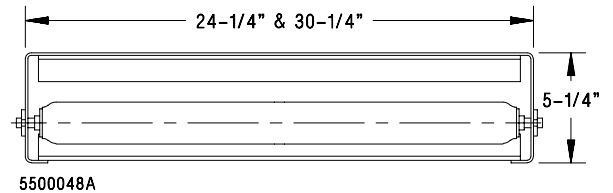

5500048A

**Return Rollers:** 1.9" diameter, 16 gage, galvanized steel with 7/16" hex SR bearings.

**End Pulley:** 6" diameter. 2-15/16" diameter shaft with 1-15/16" diameter ends, mounted in self-aligning bearings. With or without pop-out roller. Take-up adjustment is  $\pm 2"$ .

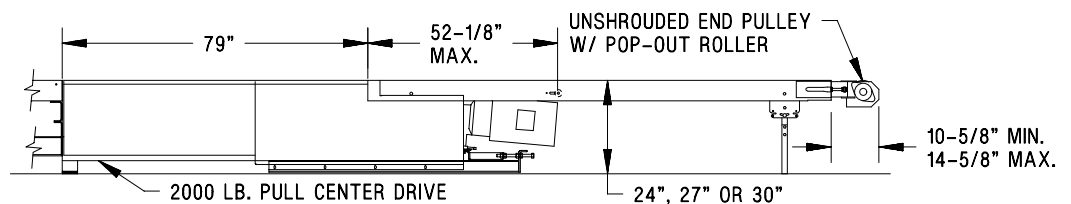
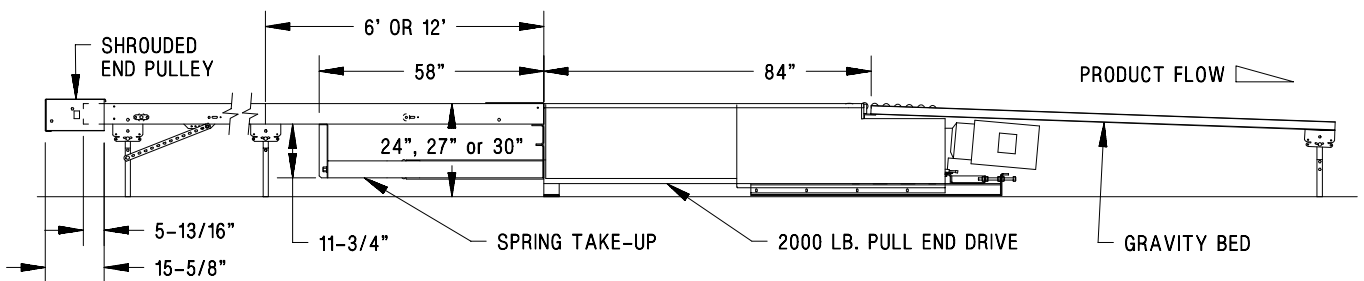

5500046C.CGM

**Model 406  
Walk Pick Conveyor**

**Materials Handling Products**

**Bed Lengths:** 12'. Other lengths available.

**Belt:** PVC-impregnated polyester carcass with low friction surfaces.

**Shrouded End Pulley:** 6" diameter, enclosed. 2-3/16" diameter shaft with 1-1/4" ends.

**Take-up:** 72" of belt take-up, spring tensioned or air operated.

**Bed:** Painted, 12-gage steel, 5-1/4" deep box type with welded angle stiffeners in 30-1/4" wide.

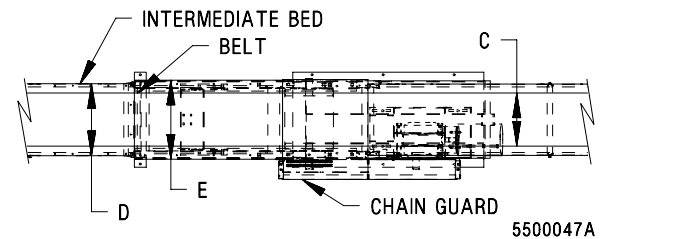

D Bed	E Drive	C Belt
24-1/4"	26-1/8"	18"
30-1/4"	32-1/8"	24"

**Options**

**Beds:** 10 gage for 30-1/4" width and channel stiffeners in extra heavy duty beds.

**Double End Pulley:** Directly couples abutting 406

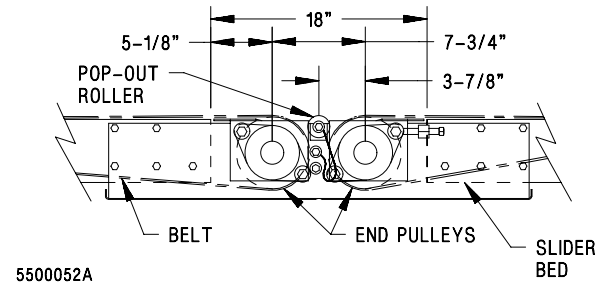

**Conveying Height Surface: 21" (Special)**